

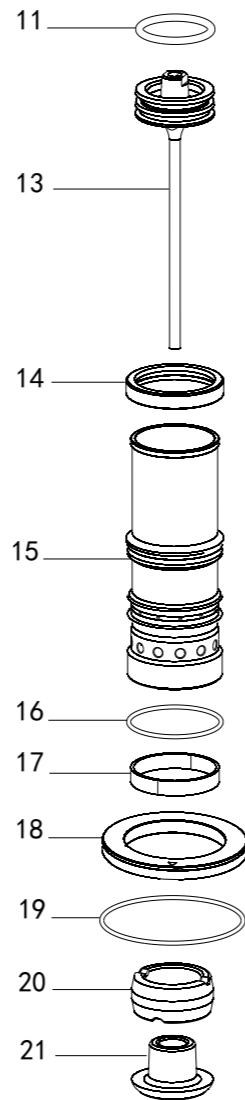

Ref. No. Part No. Description

001	2MV57-A082	Hex. Soc. Hd. Bolt
002	2MV80-A005	Protection
003	2MV70-A003	Cap
004	2MV80-A007	Gasket
005	2MCN2970-A107	Seal
006	2MCN2970-A108	Compression Spring
007	2MCN2970-A110	Washer
008	2MV57-A011	O-Ring
009	2MV70-A009	O-Ring
010	2MV70-A010	Head Valve Piston
011	2MV80-A015	O-Ring
013	2MV70-A013	Driver Unit
014	2MCN2970-A115	Collar
015	2MV70-A015	Cylinder
016	2MV80-A012	O-Ring
017	2MV80-A022	Cylinder Band
018	2MV80-A023	Cylinder Ring
019	2MV80-A024	O-Ring
020	2MCN2970-A121	Bumper-A
021	2MCN2970-A122	Bumper-B
022	2MCN2970-A442	Bolt Cap
023	2MCN2970-A441	Spring Cover
024	2MCN2970-A423	Safety
025	2MCN2970-A424	Safety Spring
026	2MV70-A026	Pin-Nail Stop
027	2MV70-A027	Door
028	2MCN3165-A211	Spring Pin
029	2MV80-A034	Latch Spring
030	2MCN2970-A413	Door Latch
031	2MV80-A036	Pin
032	2MCN2970-A419	Nail Stop
033	2MV80-A038	Spring
034	2MV80-A039	Hex. Soc. Hd. Bolt
035	2MV70-A035	Nose Piece
036	2MV80-A041	O-Ring
037	2MCN2970-A123	Grommet A
038	2MCN2970-A124	Door Shaft Pin
039	2MCN3165-A216	Spring Pin
040	2MCN2970-A435	Pin Feed Piston
041	2MCN2970-A437	Feed Finger Spring
042	2MV80-A047	Feed Finger
043	2MV70-A043	Feed Piston
044	2MCN2970-A409	Pusher Spring
045	2MV70-A045	Feed Bumper
046	2MV70-A046	Feed Piston Cap
047	2MCN2970-A411	C-Ring
048	2MV80-A093	Hex. Soc. Hd. Bolt
049	2MCN2970-A416	Pu Retainer
050	2MV80-A056	O-Ring
051	2MV80-A055	O-Ring
052	2MV80-A057	Body
053	2MCN2970-A402	O-Ring
054	2MV57-A084	Trigger Valve Head
055	2MV57-A065	Plunger
056	2MV57-A066	O-Ring
057	2MV57-A064	Spring
058	2MV57-A061	Valve Plunger
059	2MV57-A063	O-Ring
060	2MV57-A060	O-Ring
061	2MCN2970-A211	Pin
062	2MV57-A070	Plunger Cap
063	2MV57-A067	O-Ring
064	2MV57-A069	O-Ring
065	2MCN2970-A425	Safety Guide
067	2MV80-A073	Roll Pin
068	2MV80-A074	Roll Pin
069	2MV80-A075	Handle Grip
070	2MV70-A101	Trigger Assy
071	2MV70-A102	Sequential Trigger
073	2MV80-A082	C-Ring
074	2MV80-A079	Filter
075	2MV80-A080	End Cap
076	2MV80-A081	O-Ring
078	2MV70-A078	Magazine Cover
079	2MV57-A072	Spring Base
080	2MV70-A080	Spacer
081	2MCN2970-A433	Spring
082	2MV70-A082	Magazine Post
083	2MV57-A062	O-Ring
085	2MCN2970-A443	Magazine Shaft Pin

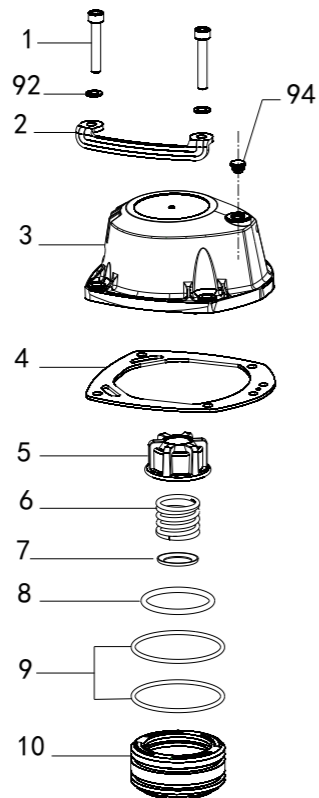

Kit Guarnizioni / Kit O-Rings



2MV70-K100

086	2MV70-A086	Magazine Case
087	2MV70-A087	Washer
088	2MCN2970-A421	Muzzle Protector
089	2MCN2970-A439	Protector Washer
090	2MV80-A096	Dust Shield Plug
091	2MV80-A004	Hex. Soc. Hd. Bolt
092	2MV57-A002	Washer
094	2MCN2970-A103	Grommet
095	2MV57-A087	Pu Retainer
096	2MV80-A103	Pin
100	2MV57-A100	Trigger Valve Assy
K100	2MV70-K100	Kit O-Ring

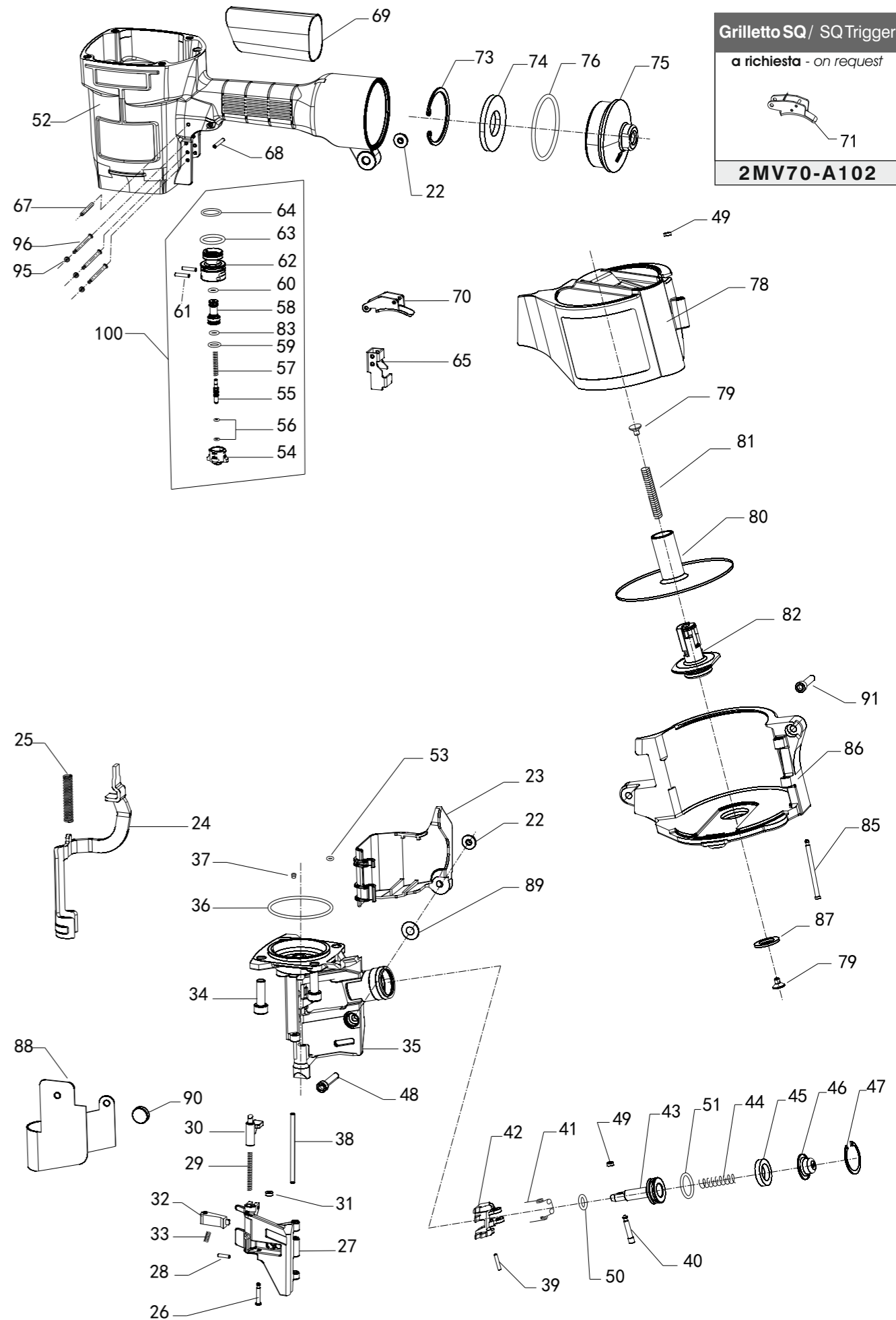

Grilletto SQ/ SQ Trigger

a richiesta - on request



2MV70-A102

## Disinzeppamento - Jam clearing

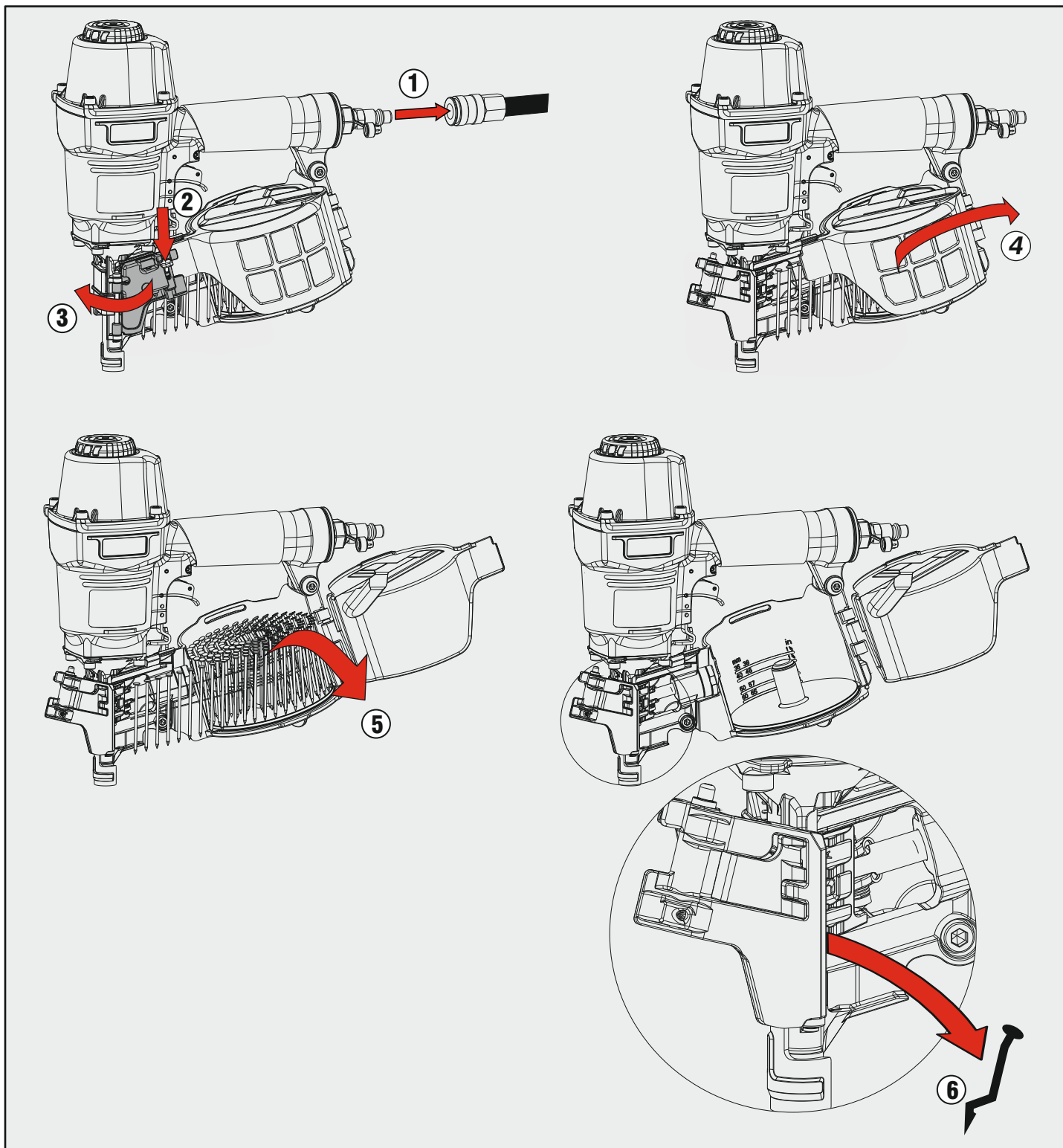

## Accessori a richiesta - Upon request accessories

**Supporto bilanciere**  
Tool hanger

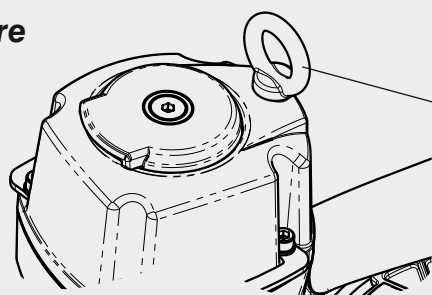

## Azionamento - Actuation

### Azionamento a contatto Contact actuation

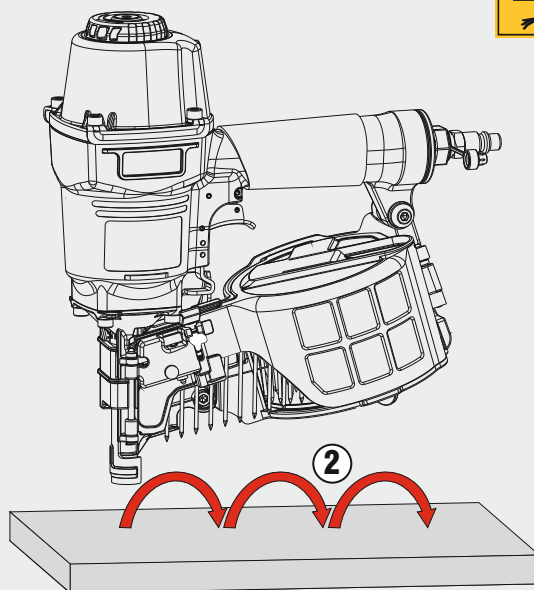
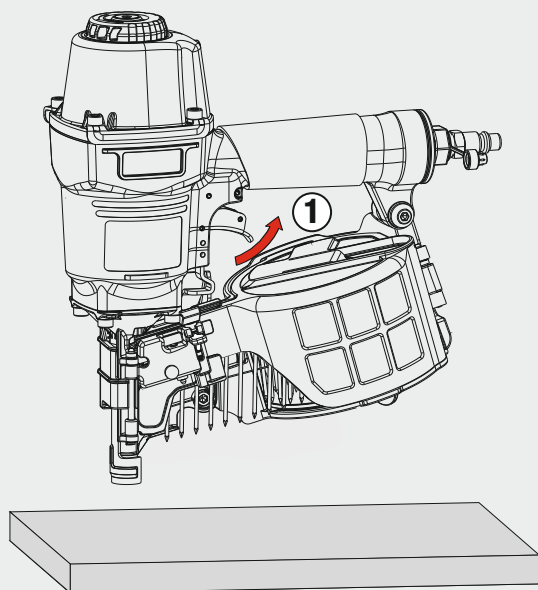

Oppure - Or

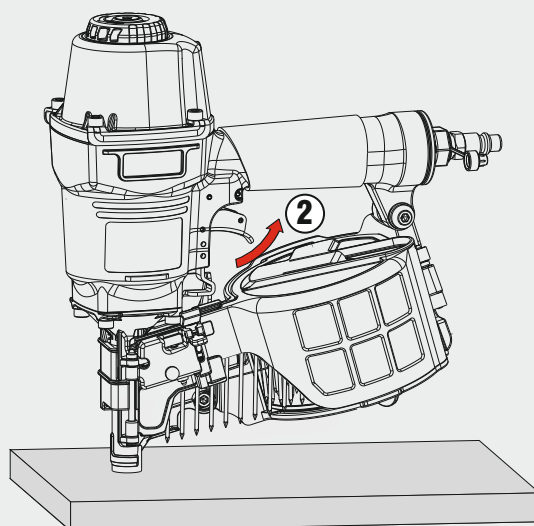
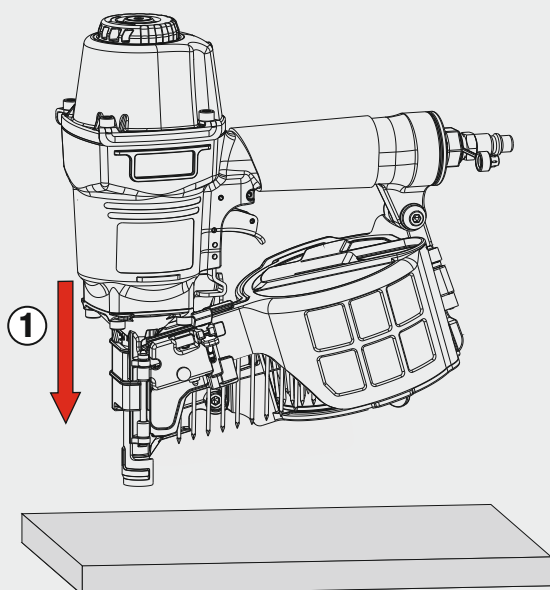

## Dotazioni - Equipment

