

## Dati tecnici - Technical data

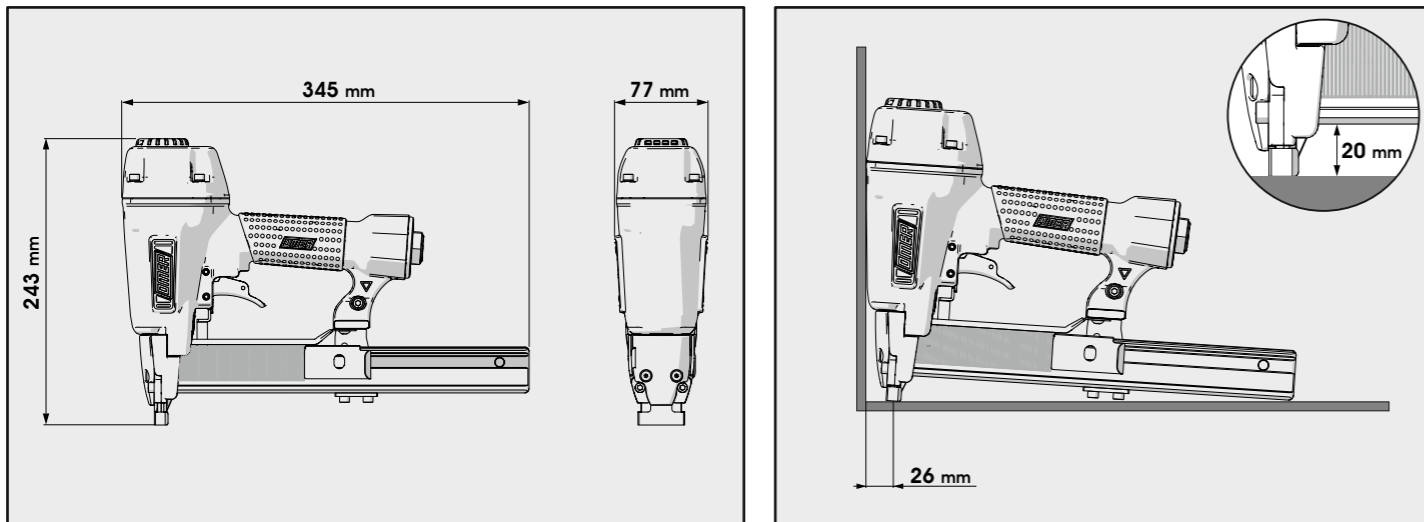

## Caratteristiche - Features

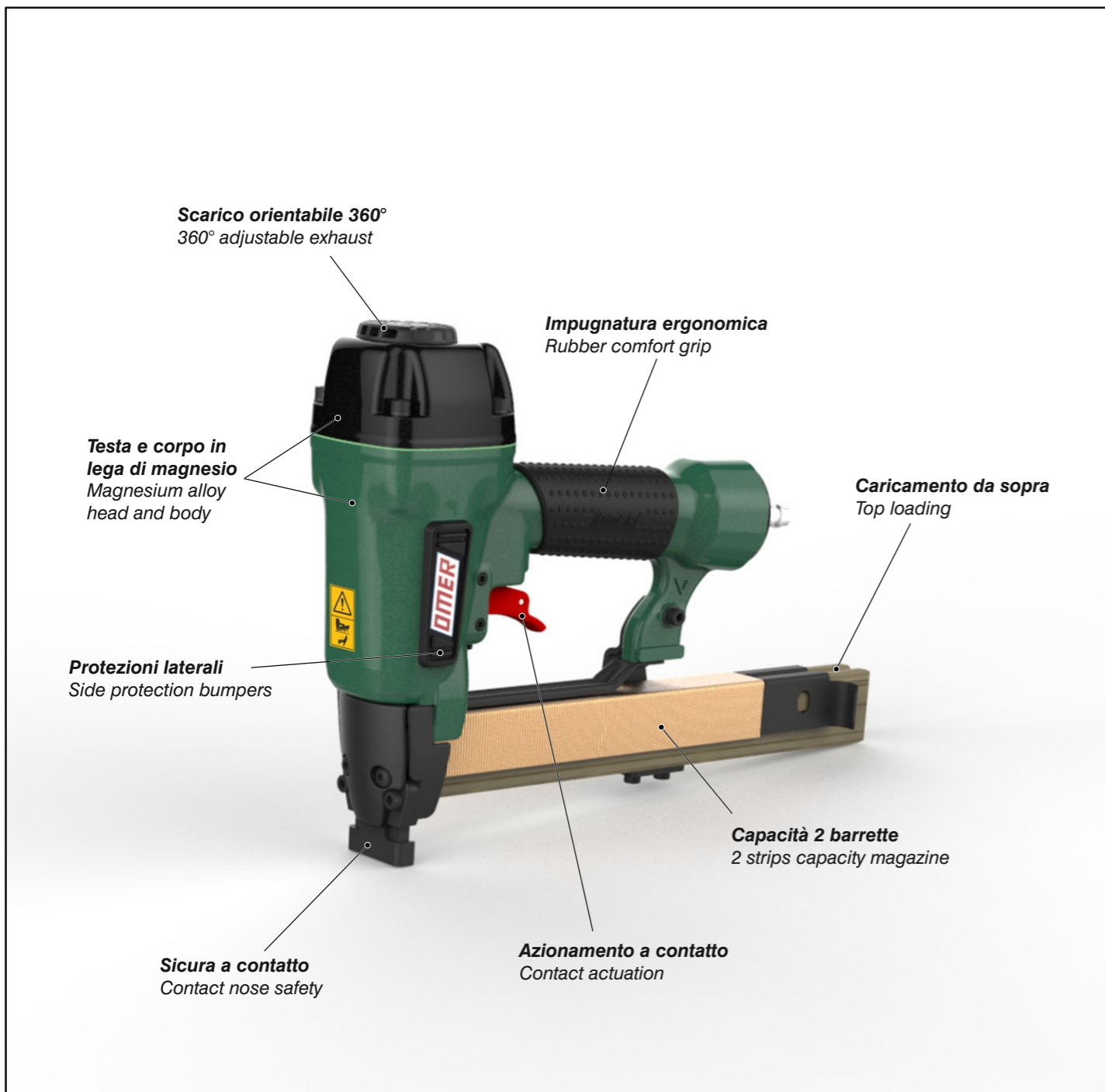

# OMER®

**Manuale d'uso, manutenzione e parti di ricambio**  
**Use, maintenance and spare parts manual**  
**Gebrauchsanweisung, Instandhaltungsrichtlinien und Ersatzteile**  
**Manuel d'utilisation, entretien et pièces de rechange**  
**Manual de uso, mantenimiento y repuestos**  
**Εγχειρίδιο χρήσης, συντήρησης και ανταλλακτικών**  
**Manual de utilização, manutenção e partes sobresselentes**  
**Handleiding voor gebruik, onderhoud en wisselstukken**  
**Brugsanvisning, vedligeholdelse og reservedelsliste**

**Parte 2**  
**Part 2**  
**Teil 2**  
**Partie 2**  
**Part 2**  
**2° Μέρος**  
**Parte 2**  
**Deel 2**  
**Del 2**



# 590.738

cod. 1748710

1748710\_590738\_4 170420 FL



**Warning:** Please read the instructions and warnings for this tool carefully before use. Failure to do so could lead to serious injury.

Dati tecnici Technical data Technische daten	Données techniques Datos técnicos Τεχνικά χαρακτηριστικά	Dados técnicos Technische gegevens Tehniske data	
<b>Misure impiegabili mm</b> Usable lengths mm Gebrauchliche Längen mm	Mesures utilisables mm Medidas que se pueden emplear mm Διαστάσεις σε μμ	Medidas que se podem utilizar mm Te gebruiken engtes in mm Brugbare længder i mm	<b>15 ÷ 38</b>
<b>Capacità caricatore n° punti</b> Magazine capacity No. of fasteners Magazinkapazität Nägel	Capacité chargeur n° de points Capacidad cargador n° puntos Δυνατότητα γεμιστέρα, σπινδύτερος	Capacidade carregador n° pontos Capaciteit magazijn in aantal spijkers Kapacitet af magasin antal klemme	<b>130</b>
<b>Pressione d'esercizio</b> Working pressure Betriebsdruck	Pression de fonctionnement Presión de trabajo Πίεση λειτουργίας ατμ.	Pressao de trabalho Werkdruk Arbejds tryk bar	<b>5 ÷ 7,5 bar</b> <b>70 ÷ 105 psi</b>
<b>Consumo aria litri/colpo</b> Air consumption litres/shot Luftverbrauch Liter/Schlag	Consommation air litre/coup Consumo aire-litros/golpe Κατανοση αερα λ/ξτπημα	Consumo ar litro/golpe Luchtverbruik liter/schot Luftforbrug liter/skud	<b>0,75</b>
<b>Peso kg</b> Weight kg Gewicht kg	Poids kg Peso kg Βαρος κγ	Peso kg Gewicht in kg Vægt kg	<b>2,00</b>
<b>Dimensioni (AxBxH) mm</b> Dimensions mm Große mm	Dimension mm Dimensiones mm Δυνατότητα γεμιστέρα, σπινδύτερος	Dimencoes mm Afmetingen in mm Dimensioner mm	<b>345x77x243</b>
<b>EN 12549 :1999 ISO 11201 :1995</b>			
<b>Pressione sonora in pos. operatore</b> Sound pressure at the workstation Lärmintensität am Arbeitsplatz	Pression acoustique près de l'opérateur Presión sonora en posición encargado Ακουστική πίεση στη θέση χειριστού	Intensidade sonora perto do operador Geluidssterkte op de werkplek Lydstyrke på operatorposten	<b>86,1 dB(A)</b>
<b>EN 12549 :1999 ISO 3744 :1994</b>			
<b>Potenza sonora emessa</b> Emitted sound power Ausgestrahlte Lärmintensität	Puissance acoustique émise Potencia sonora emitida Ακουστική ισχυ	Potência sonora emitida Uitgestraalde geluidssterkte Udsendt lydstrykke	<b>94,9 dB(A)</b>
<b>EN 28662 :1992 ISO 5349 :1986 ISO 8662 -11</b>			
<b>Valore medio ponderato di vibrazione sull'impugnatura</b> Weighted mean value of vibration on the grip Mitteler Vibrationswert, am Griff gemessen	Valeur moyenne pondérée de vibration mesurée sur la poignée Valor medio ponderado de vibracion medida en la empunadura Μεσος ορος μετρησης κραδασιμον στη χειρολαβη	Valor medio ponderado de vibracao medida no punho Gewogen gemiddelde vibratiewaarde Middelvaerdi af vibrationer pa handtaget	<b>2,6 m/s<sup>2</sup></b>

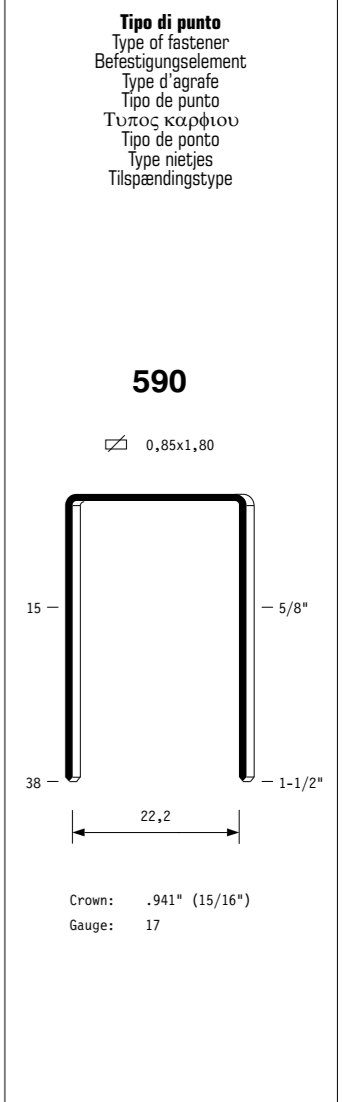



## Azionamento - Actuation

### Azionamento a contatto Contact actuation

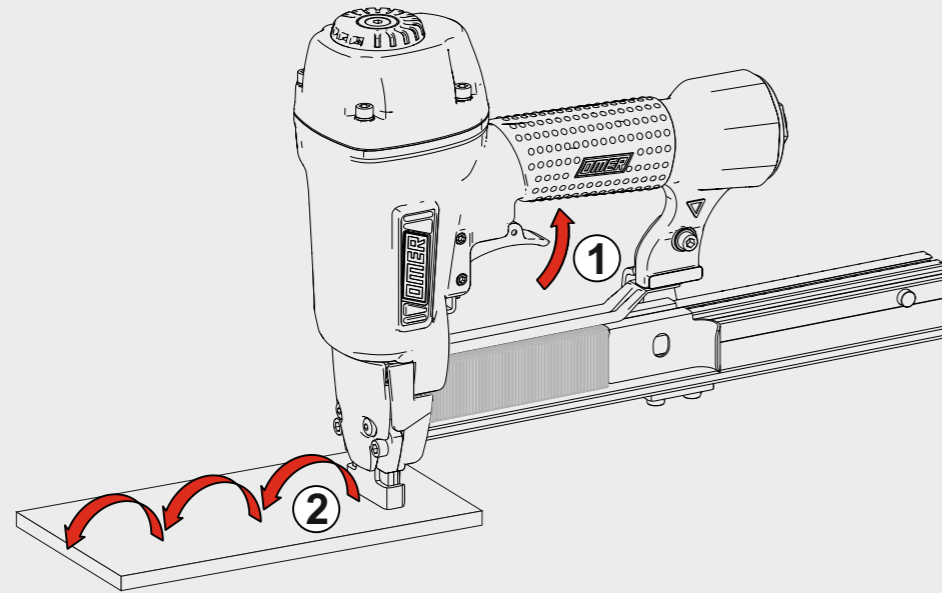

Oppure - Or

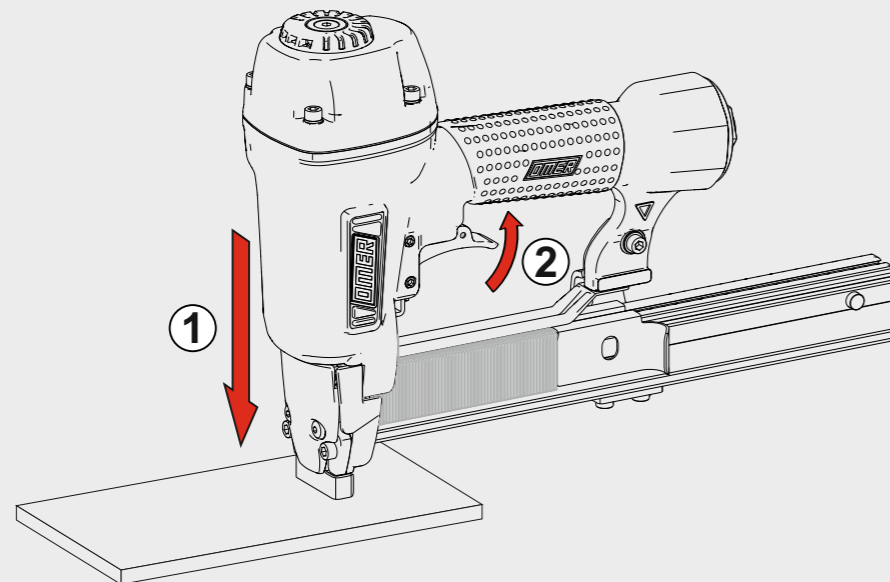

## Parti di ricambio - Spare parts - Ersatzteile - Pièces de rechange - Piezas de repuesto Ανταλλακτικά - Partes sobresselentes - Wisselstukken - Reservedele

Cod.	Descrizione	Description
00.11	O-Ring	O-Ring
00.14	O-Ring	O-Ring
00.15.2	O-Ring	O-Ring
00.18	O-Ring	O-Ring
00.22	O-Ring	O-Ring
00.45	O-Ring	O-Ring
01.35	O-Ring	O-Ring
01.48	O-Ring	O-Ring
01.51	O-Ring	O-Ring
01.64	O-Ring	O-Ring
02.38.2	O-Ring	O-Ring
02.48	O-Ring	O-Ring
03.00	Dado	Nut
03.30	Vite	Screw
04.05.5	Vite	Screw
04.19	Vite	Screw
05.00	Dado	Nut
05.14	Vite	Screw
05.16.1	Vite	Screw
05.25	Vite	Screw
05.30	Vite	Screw
06.20	Vite	Screw
06.20.2	Vite	Screw
07.25	Chiave esagonale	Hex. bar wrench
07.30	Chiave esagonale	Hex. bar wrench
07.40	Chiave esagonale	Hex. bar wrench
07.50	Chiave esagonale	Hex. bar wrench
09.24.1	Anello elastico	Elastic ring
10.55	O-Ring	O-Ring
17.27	Tappo	Inlet cap
21.76	Corpo	Body
22.74	Testa	Head
25.74	Deflettore scarico	Exhaust deflector
26.74	Cilindro	Cylinder
27.70	Anello	Ring
27.74	Anello cilindro	Cylinder ring
28.74	Guarnizione testa	Head gasket
30.75.1	Pistone	Piston
32.75.1	Ammortizzatore	Bumper
40.74	Valvola completa	Valve assembled
43.11	Rondella	Washer
44.73	Guarnizione cilindro	Cylinder gasket
44.74	Ammortizzatore sup.	Upper bumper
45.70	Distanziale	Spacer
50.74	Pulsante completo	Trigger valve assy
51.74	Boccola servovalvola	Servo valve bushing
53.74	Pistone servovalvola	Servo valve piston
54.83	Pulsante	Trigger valve
55.74	Raccordo pulsante	Trigger valve bush
64.78.1	Carter sicura	Safety guard
64.79	Carter	Hold down
69.70.4	Supporto	Support
71.76	Reggicaricatore	Support
73.71.2	Perno	Pin
75.66	Sicura	Safety
76.44	Rullo molla	Roller
77.78	Guida sicura	Safety guide
78.76	Rinvio sicura	Safety rod
81.78	Grilletto comando CT	CT Trigger
86.74	Boccola	Bushing
90.76.1	Piastra	Plate
91.00	Molla	Spring
91.73	Molla	Spring
91.77	Molla	Spring
92.73	Molla	Spring
93.73	Molla	Spring
23.70.63	Battente	Driver
54.70.60	Caricatore	Magazine
71.70.60	Spingipunto	Pusher
84.71.63	Controstestina	Nose
94.70.63	Testina	Nose plate
D01	Bocchetta olio	Oiler
D02	Occhiali protettivi	Protective goggles

Guarnizioni - O-Rings - Dichtungen - Joints - Kit O-Rings - Ααστιγασκία - Kit O-Rings - O-ringen - Pakninger

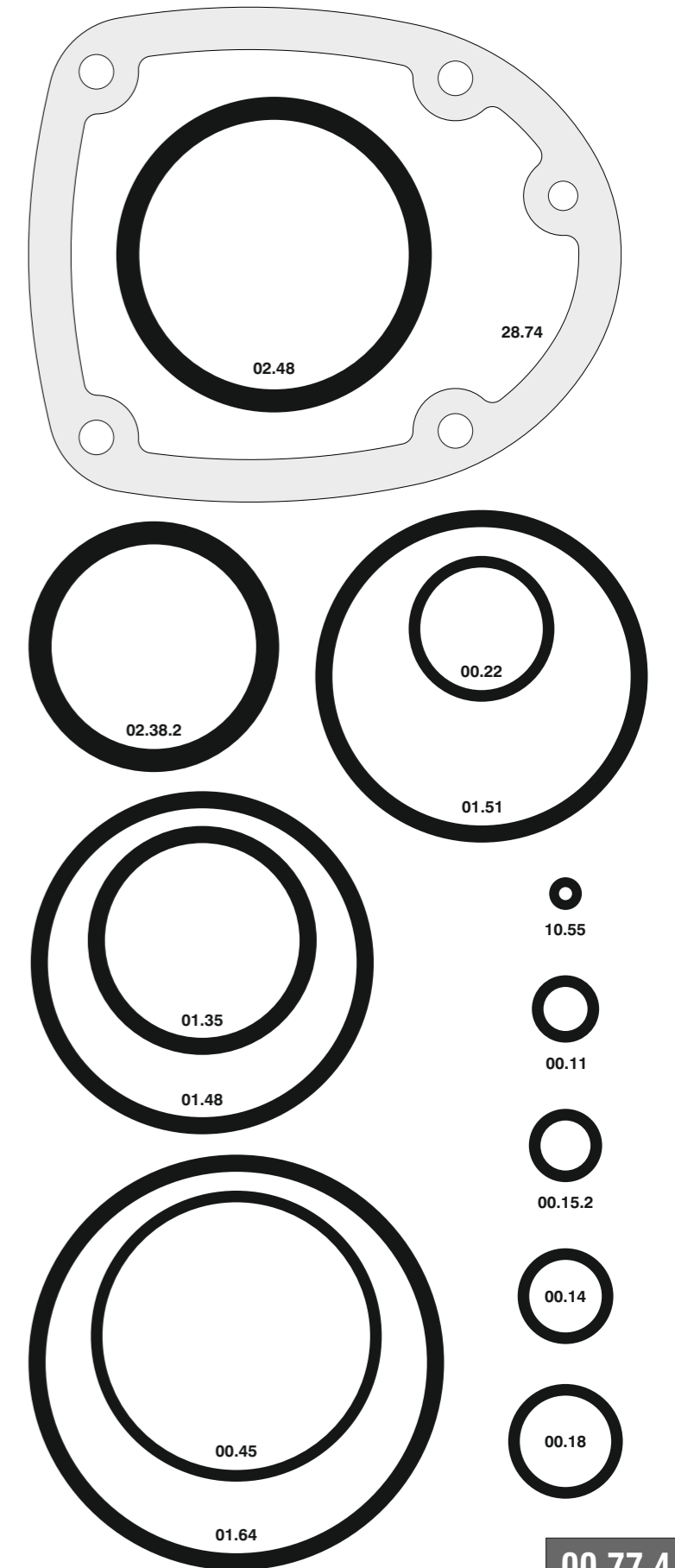

# 590.738

cod. 1748710

Indice di modifica  
Upgrade number

4

## Disinceppamento - Jam clearing

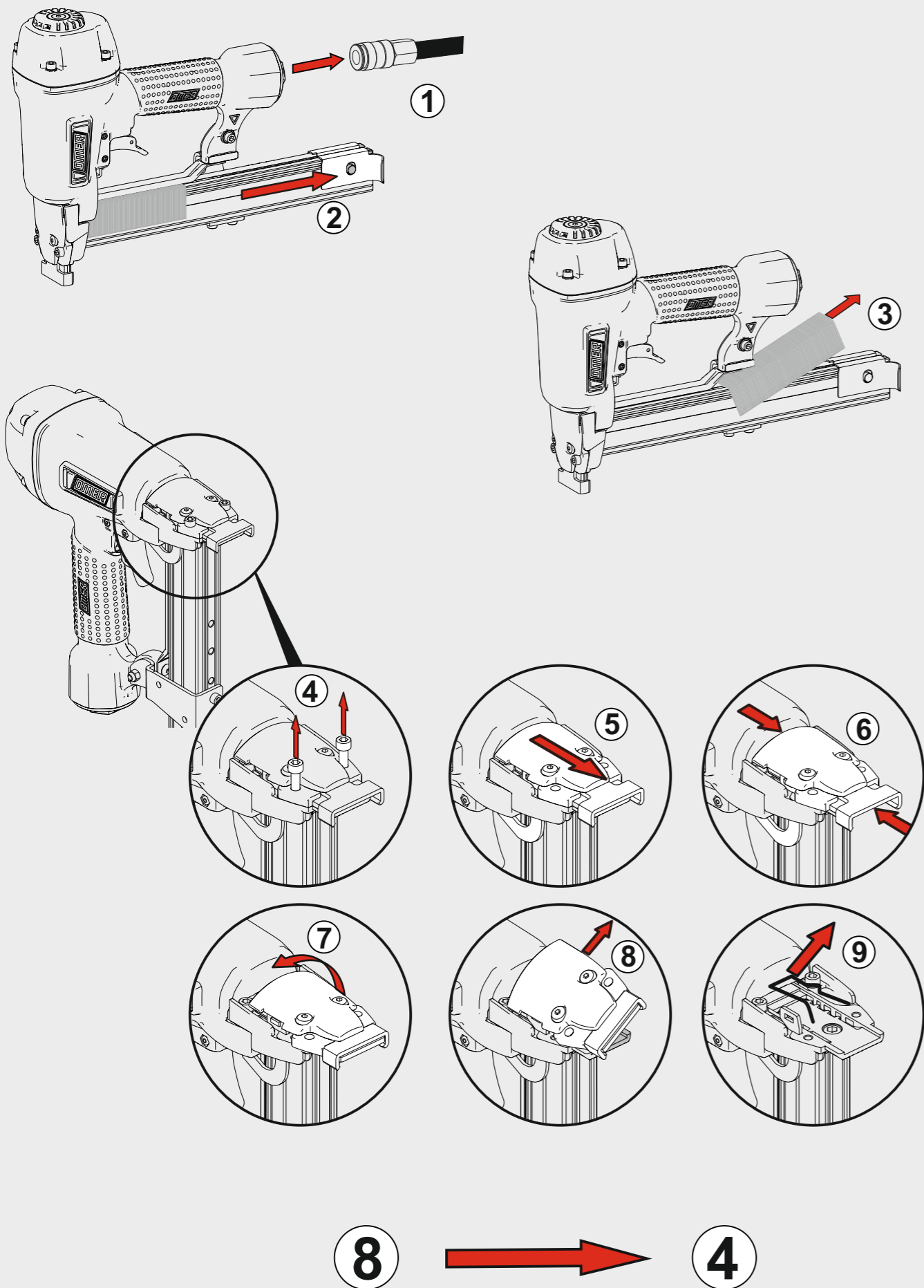

## Caricamento - Loading

