

Azionamento - Actuation

Azionamento singolo Single actuation

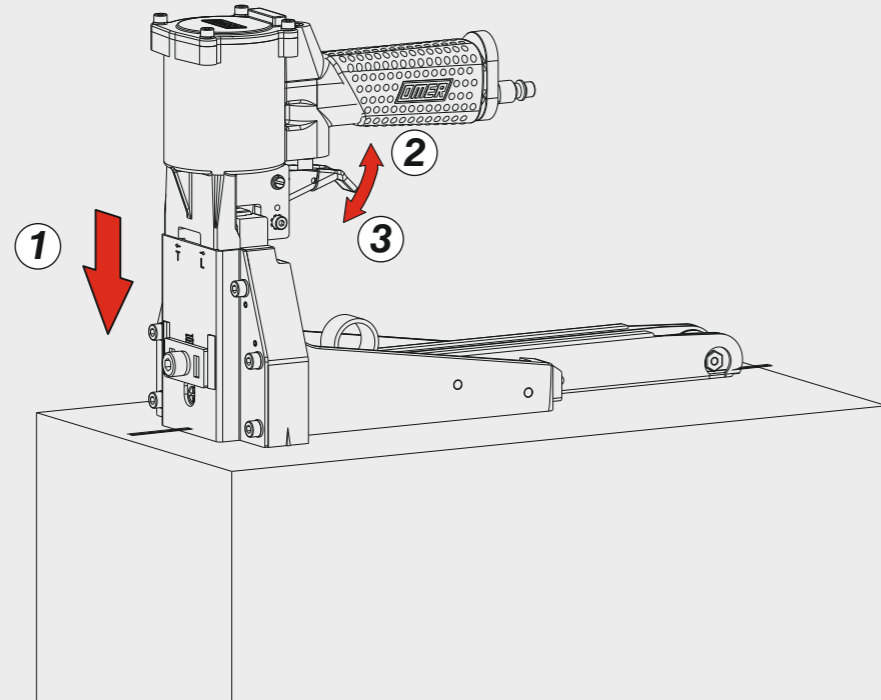

Caricamento - Loading

Caricamento da dietro Rear load magazine

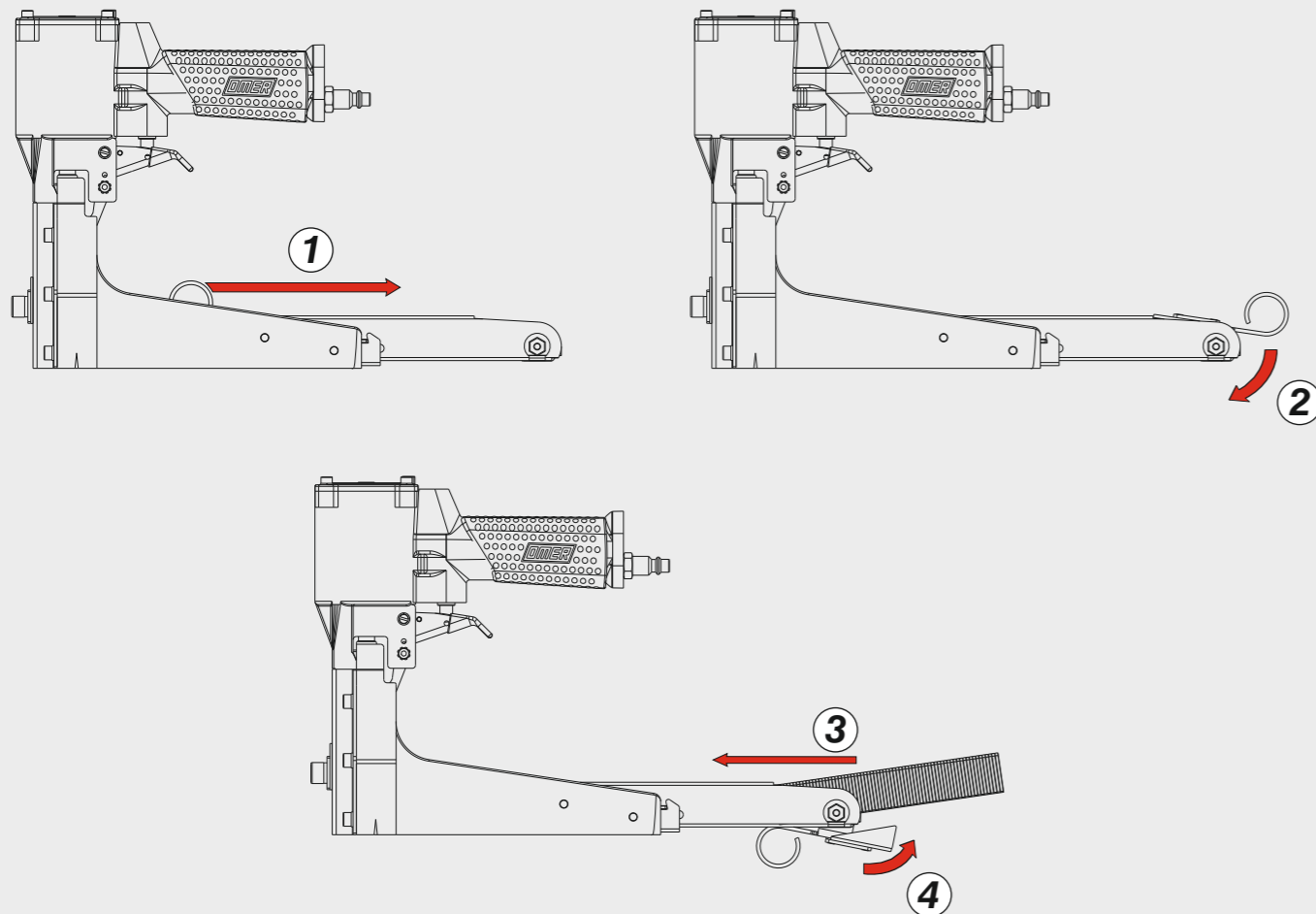

OMER[®]

Manuale d'uso, manutenzione e parti di ricambio
Use, maintenance and spare parts manual
Gebrauchsanweisung, Instandhaltungsrichtlinien und Ersatzteile
Manuel d'utilisation, entretien et pièces de rechange
Manual de uso, mantenimiento y repuestos
 Εγχειρίδιο χρήσης, συντηρησης και ανταλλακτικών
Manual de utilização, manutenção e partes sobresselentes
Handleiding voor gebruik, onderhoud en wisselstukken
Brugsanvisning, vedligeholdelse og reservedelsliste

Parte 2
Part 2
Teil 2
Partie 2
Part 2
 2° Μέρος
Parte 2
Deel 2
Del 2

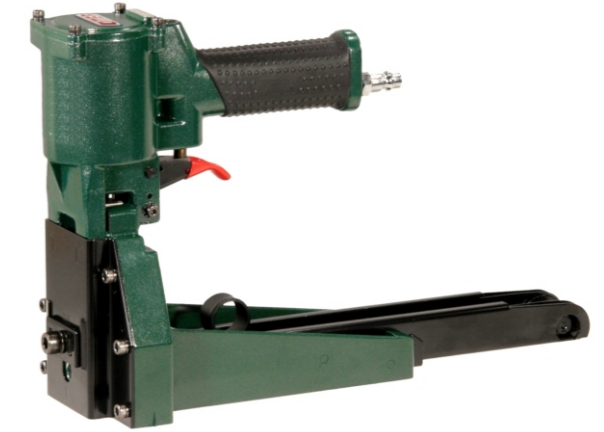

35.18

cod. 19818T3

19818T3_3518_3 190220 FL



Dati tecnici

Technical data
Technische daten

Données techniques
Datos técnicos
Τεχνικά χαρακτηριστικά

Dados técnicos
Technische gegevens
Teknische data

Misure impiegabili mm Usable lengths mm Gebrauchliche Längen mm	Mesures utilisables mm Medidas que se pueden emplear mm Διαστάσεις σε μμ	Medidas que se podem utilizar mm Te gebruiken engtes in mm Brugbare længder i mm	15 ÷ 18
Capacità caricatore n° punti Magazine capacity No. of fasteners Magazinkapazität Nägel	Capacité chargeur n° de points Capacidad cargador n° puntos Δυνατότητα γεμιστέρα, σπινδύτερος	Capacidade carregador n° pontos Capaciteit magazijn in aantal spijkers Kapacitet af magasin antal klemme	100
Pressione d'esercizio Working pressure Betriebsdruck	Pression de fonctionnement Presión de trabajo Πίεση λειτουργίας ατμ.	Pressao de trabalho Werkdruk Arbejds tryk bar	5 ÷ 7 bar 70 ÷ 100 psi
Consumo aria litri/colpo Air consumption litres/shot Luftverbrauch Liter/Schlag	Consommation air litre/coup Consumo aire-litros/golpe Καταναλοση αερα λ/ξτπημα	Consumo ar litro/golpe Luchtverbruik liter/schot Luftforbrug liter/skud	1,32
Peso kg Weight kg Gewicht kg	Poids kg Peso kg Βαρος κγ	Peso kg Gewicht in kg Vægt kg	2,45
Dimensioni (AxBxH) mm Dimensions mm Größe mm	Dimension mm Dimensiones mm Δυνατότητα γεμιστέρα, σπινδύτερος	Dimencoes mm Afmetingen in mm Dimensioner mm	342x115x222
EN 12549 :1999 ISO 11201 :1995			
Pressione sonora in pos. operatore Sound pressure at the workstation Lärmintensität am Arbeitsplatz	Pression acoustique près de l'opérateur Presión sonora en posición encargado Ακουστική πίεση στη θέση χειριστου	Intensidade sonora perto do operador Geluidssterkte op de werkplek Lydstyrke på operatorposten	84,3 dB(A)
EN 12549 :1999 ISO 3744 :1994			
Potenza sonora emessa Emitted sound power Ausgestrahlte Lärmintensität	Puissance acoustique émise Potencia sonora emitida Ακουστική ισχυ	Potência sonora emitida Uitgestraalde geluidssterkte Udsendt lydstryrke	93,7 dB(A)
EN 28662 :1992 ISO 5349 :1986 ISO 8662 -11			
Valore medio ponderato di vibrazione sull'impugnatura Weighted mean value of vibration on the grip Mitteler Vibrationswert, am Griff gemessen	Valeur moyenne pondérée de vibration mesurée sur la poignée Valor medio ponderado de vibracion medida en la empunadura Μεσος ορος μετρησης κραδασιμον στη χειρολαβη	Valor medio ponderado de vibracao medida no punho Gewogen gemiddelde vibratiewaarde Middelvaerdi af vibrationer på handtaget	<2,5 m/s²

Tipo di punto
Type of fastener
Befestigungselement
Type d'agrafe
Tipo de punto
Τυπος καρφιου
Tipo de ponto
Type nietjes
Tilspændingstype

35

0,80x2,20

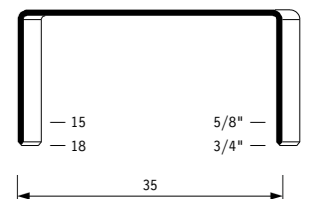

Crown: 1.378" (1-3/8")
Gauge: 16

Parti di ricambio - Spare parts - Ersatzteile - Pièces de rechange - Piezas de repuesto
 Ανταλλακτικά - Partes sobresselentes - Wisselstukken - Reservedele

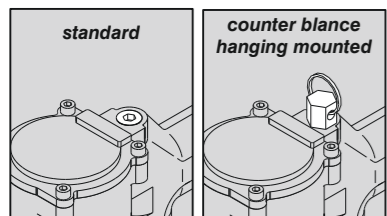
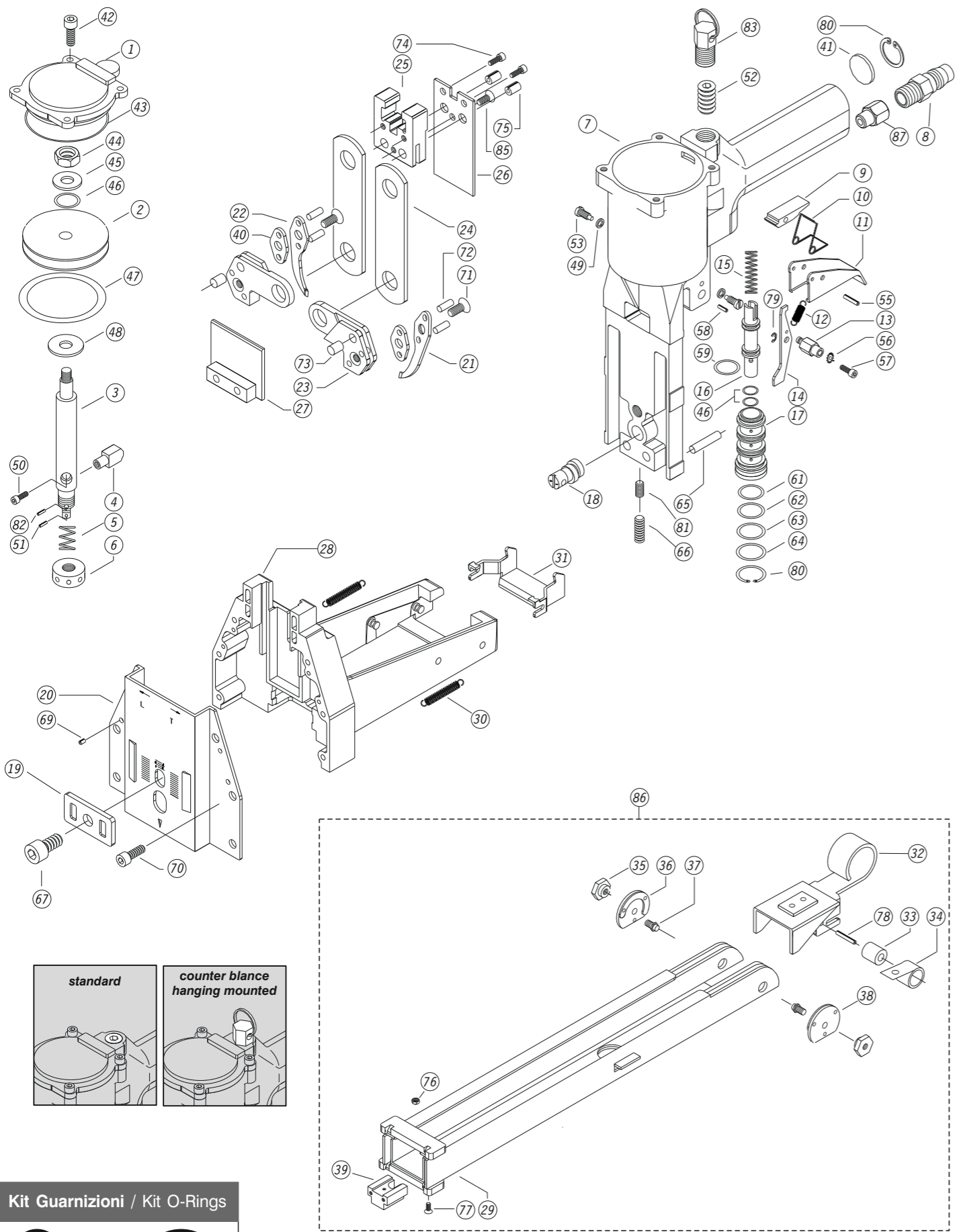

35.18
 cod. 19818T3

Regolazione della chiusura - *Clinching adjustment*

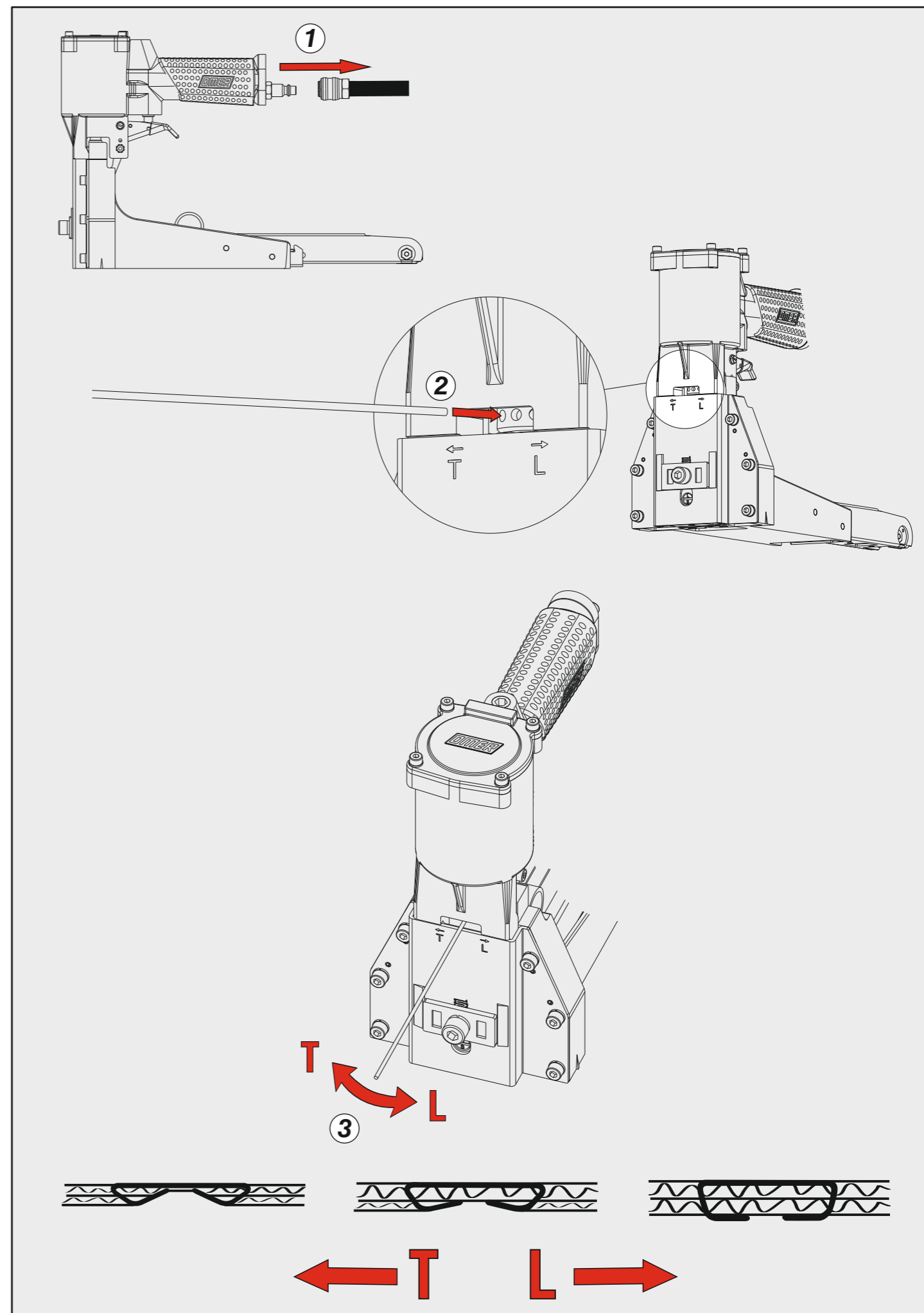

Regolazione di profondità - Depth adjustment

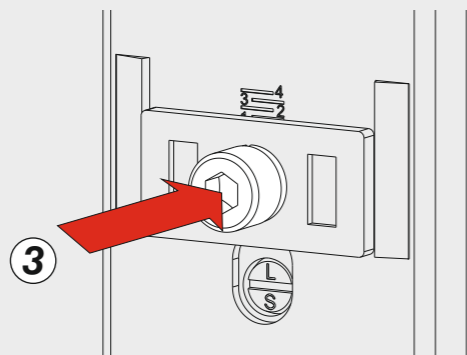
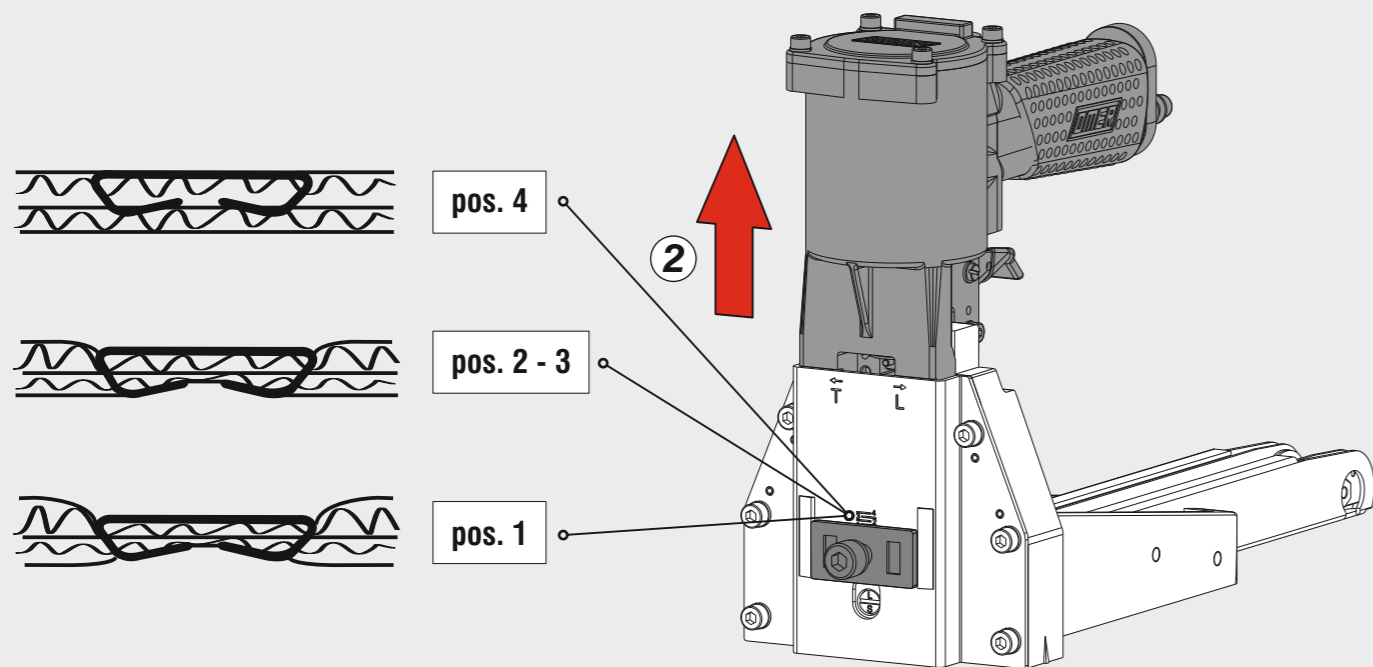
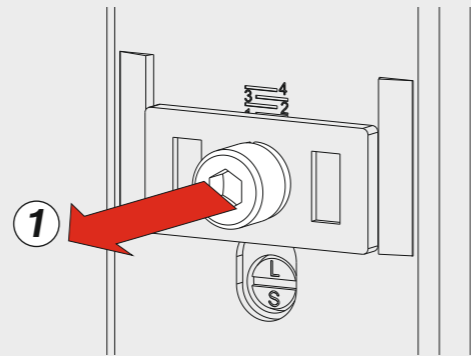
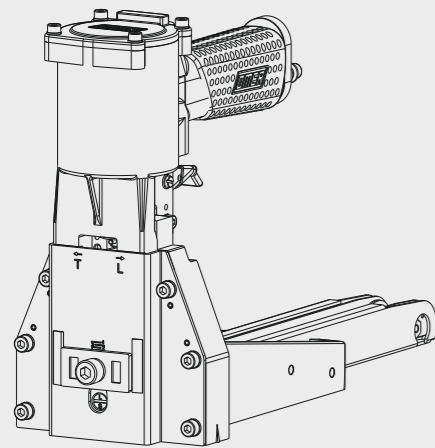

Ref. No.	Part No.	Description	Ref. No.	Part No.	Description	Ref. No.	Part No.	Description
1	32P501	Cap	31	32M523	Bracket	63	35P060	O-Ring
2	35P002N	Piston	32	35P035	Pusher Unit	64	35P061	O-Ring
3	35P003N	Piston Rod	33	35P034	Roller	65	35P062	Rod
4	35P004	Block	34	35P033	Spring	66	35P063	Screw
5	35P005	Spring	35	32P535	Rod Nut	67	35P064	Screw
6	35P006	Collar	36	35P037	Right pusher guide	69	35P066	Spring Pin
7	35P007N	Body	37	35P032	Rod	70	32P570	Screw
8	35P008	Air Plug	38	35M032	Left pusher guide	71	35P069	Screw
9	35P009	Block	39	34P339	Bracket	72	35P070	Pin
10	35P010	Spring	40	35P039	Washer	73	35P071	Pin
11	35P011	Trigger	41	32P541	Silencer	74	35M046N	Screw
12	35P012	Spring	42	35P040N	Screw	75	35P072	Spring Pin
13	35P013	Rod	43	35P042N	O-Ring	76	35P076	Lock Nut
14	35P014	Trigger's control	44	35P043	Nut	77	32P577	Screw
15	35P015	Spring	45	35P044	Washer	78	32M549	Spring Pin
16	35P016	Valve	46	35P045	O-Ring	79	35P081	E-Ring
17	35P017N	Tube	47	35P046N	O-Ring	80	35P080N	C-Ring
18	35P018	Adjusting Rod	48	35P047	Washer	81	35P084	Heli-Coil
19	35P019	Adjusting Plate	49	35P041	Spring Washer	82	35P085	Plastic Pin
20	32P520	Front plate	50	35P048	Screw	83	19B091	Counter Balance Hanger
21	35P021	Right jaw	51	35P049	Spring Pin	85	32P585	Screw
22	35P022	Left jaw	52	35P050	Screw	86	35M321	Magazine Ass'y
23	35P023	Jaw seat	53	35P051	Trigger Screw	87	34P387	Adaptor
24	35P024	Plate	55	35P052	Spring Pin	07.25		Hex. Bar wrench
25	32P525	Block	56	35P053	Teeth Washer	07.30		Hex. Bar wrench
26	35M518	Driver	57	35P054	Screw	07.40		Hex. Bar wrench
27	35P027	Cover Unit	58	35P066	Spring Pin	D01		Oiler
28	32M320	Magazine Seat	59	35P056	O-Ring	D06		Staple remover
29	35P329	Magazine	61	35P058	O-Ring			
30	32M522	Spring	62	35P059	O-Ring			

Dotazioni - Equipment - Ausrüstung - Équipements - Equipamiento - Παρεχόμενα Equipamento - Uitrusting - Udstyr

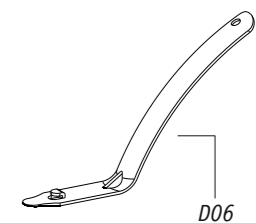
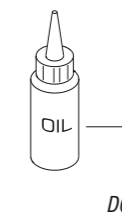

Disinceppamento - Jam clearing

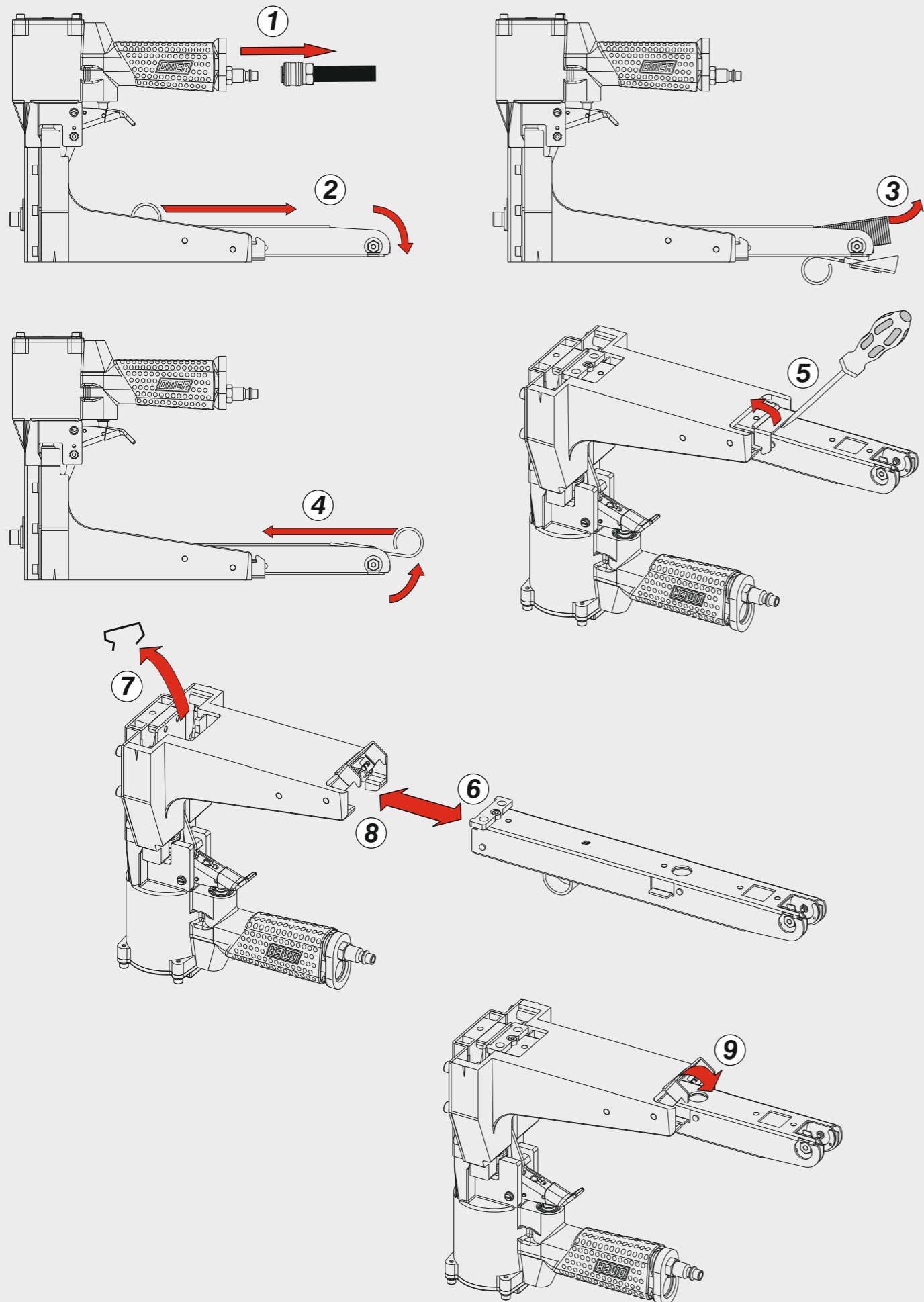

Regolazione lunghezza graffa - Staple length adjustment

