

Azionamento - Actuation

Azionamento sequenziale singolo Single sequential actuation

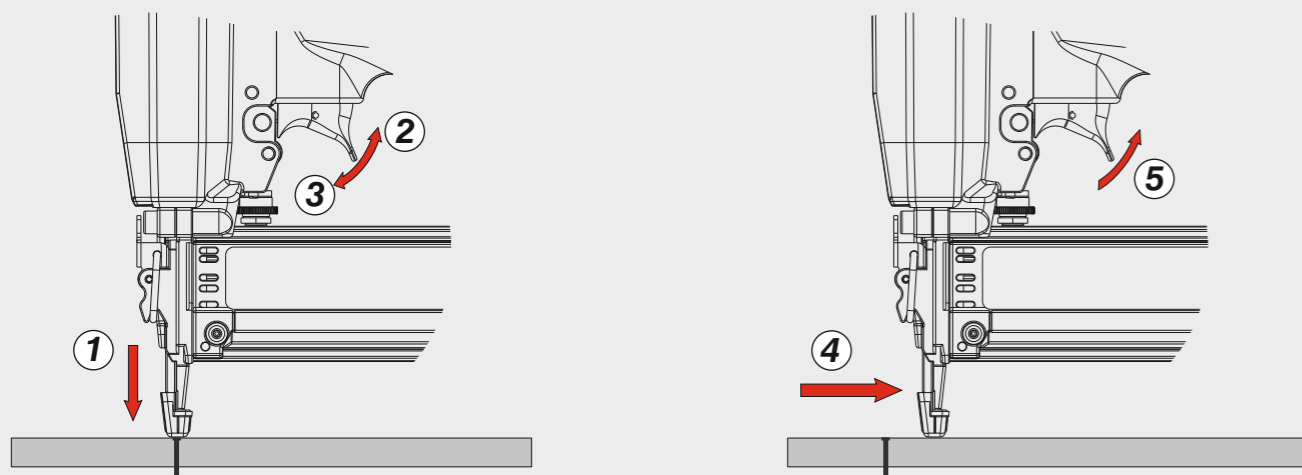

Caricamento - Loading

Caricamento dal fianco Side load magazine

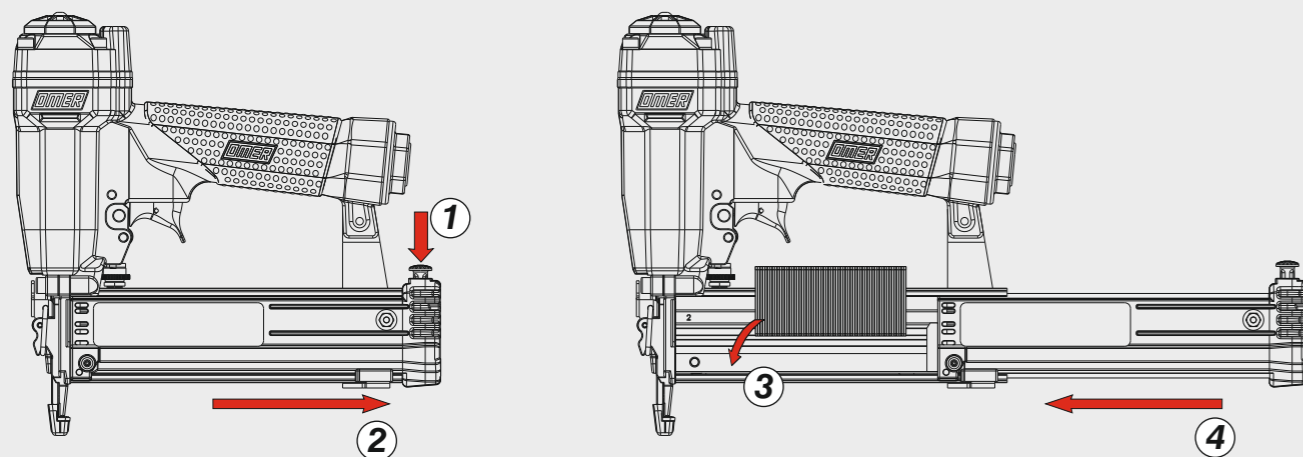

Regolazione di profondità - Depth adjustment

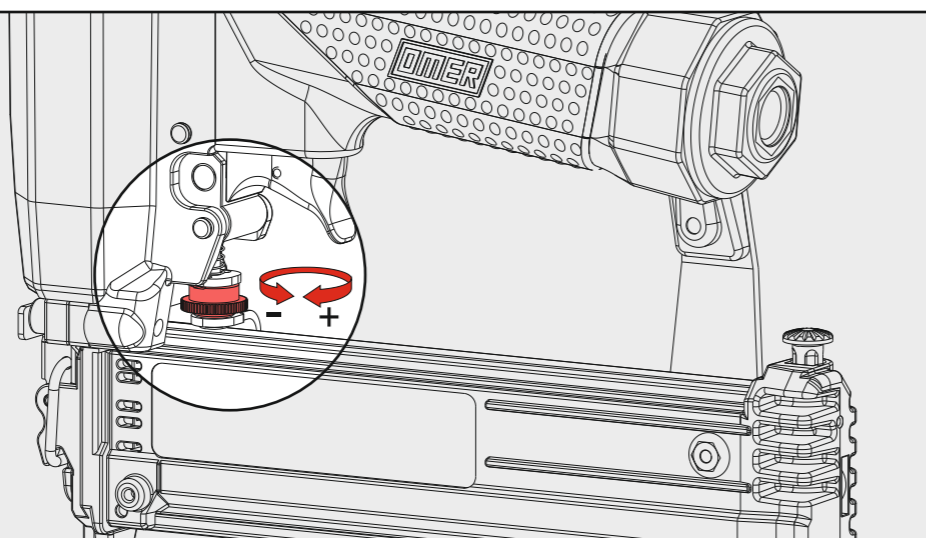
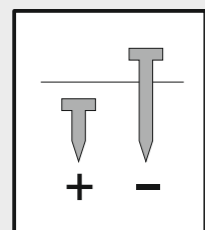

OMER

Manuale d'uso, manutenzione e parti di ricambio
Use, maintenance and spare parts manual
Gebrauchsanweisung, Instandhaltungsrichtlinien und Ersatzteile
Manuel d'utilisation, entretien et pièces de rechange
Manual de uso, mantenimiento y repuestos
 Εγχειρίδιο χρήσης, συντηρησης και ανταλλακτικών
Manual de utilização, manutenção e partes sobresselentes
Handleiding voor gebruik, onderhoud en wisselstukken
Brugsanvisning, vedligeholdelse og reservedelsliste

Parte 2
Part 2
Teil 2
Partie 2
Part 2
 2° Μέρος
Parte 2
Deel 2
Del 2



12.40

cod. 1221210

1221210_1240_2 150120 IV



Dati tecnici Technical data Technische daten	Données techniques Datos técnicos Τεχνικά χαρακτηριστικά	Dados técnicos Technische gegevens Teknische data
--	--	---

Misure impiegabili mm Usable lengths mm Gebrauchliche Längen mm	Mesures utilisables mm Medidas que se pueden emplear mm Διαστάσεις σε μμ	Medidas que se podem utilizar mm Te gebruiken lengtes in mm Brugbare længder i mm	12 ÷ 40
Capacità caricatore n° punti Magazine capacity No. of fasteners Magazinkapazität Nägel	Capacité chargeur n° de points Capacidad cargador n° puntos Δυνατότητα γεμιστέρα, σπινδύτερος	Capacidade carregador n° pontos Capaciteit magazijn in aantal spijkers Kapacitet af magasin antal klemme	100
Pressione d'esercizio Working pressure Betriebsdruck	Pression de fonctionnement Presión de trabajo Πίεση λειτουργίας ατμ.	Pressao de trabalho Werkdruk Arbejds tryk bar	5 ÷ 7,5 bar 70 ÷ 105 psi
Consumo aria litri/colpo Air consumption litres/shot Luftverbrauch Liter/Schlag	Consommation air litre/coup Consumo aire-litros/golpe Κατανοση αερα λ/ξτπημα	Consumo ar litro/golpe Luchtverbruik liter/schot Luftforbrug liter/skud	0,34
Peso kg Weight kg Gewicht kg	Poids kg Peso kg Βαρος κγ	Peso kg Gewicht in kg Vægt kg	1,15
Dimensioni (AxBxH) mm Dimensions mm Größe mm	Dimension mm Dimensiones mm Δυνατότητα γεμιστέρα, σπινδύτερος	Dimencoes mm Afmetingen in mm Dimensioner mm	226x50x223

EN 12549 :1999	ISO 11201 :1995	
Pressione sonora in pos. operatore Sound pressure at the workstation Lärmintensität am Arbeitsplatz	Pression acoustique près de l'opérateur Presión sonora en posición encargado Ακουστική πίεση στη θέση χειριστού	Intensidade sonora perto do operador Geluidssterkte op de werkplek Lydstyrke på operatorposten
		$L_{pA, 1s}$ (Rif. 20μPa) 78,8 dB(A)

EN 12549 :1999	ISO 3744 :1994	
Potenza sonora emessa Emitted sound power Ausgestrahlte Lärmintensität	Puissance acoustique émise Potencia sonora emitida Ακουστική ισχυ	Potência sonora emitida Uitgestraalde geluidssterkte Udsendt lydstyrke
		$L_{WA, 1s}$ (Rif. 1pW) 88,5 dB(A)

EN 28662 :1992	ISO 5349 :1986	ISO 8662 -11
Valore medio ponderato di vibrazione sull'impugnatura max.33 colpi Weighted mean value of vibration on the grip max.33 shots Mitteler Vibrationswert, am Griff gemessen max.33 Schläge	Valeur moyenne pondérée de vibration mesurée sur la poignée max.33 coups Valor medio ponderado de vibracion medida en la empunadura max.33 golp Μεσος ορος μετρησης κραδασιμον στη χειρολαβη μαξ.33 ξτπημα	Valor medio ponderado de vibracao medida no punho max.33 golpes Gewogen gemiddelde vibratiewaarde max.33 schot Middelvaerdi af vibrationer på handtaget max.33 skud
		<2,5 m/s²

Tipo di punto
Type of fastener
Befestigungselement
Type d'agrafe
Tipo de punto
Τυπος καρφιου
Tipo de ponto
Type nietjes
Tilspændingstype

Brads 12

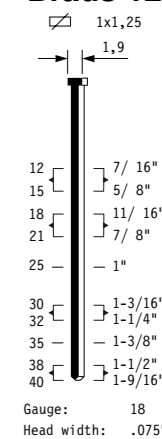

Pins I

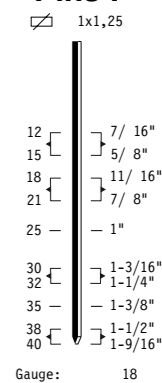

Parti di ricambio - Spare parts - Ersatzteile - Pièces de rechange - Piezas de repuesto
Ανταλλακτικά - Partes sobresselentes - Wisselstukken - Reservedele

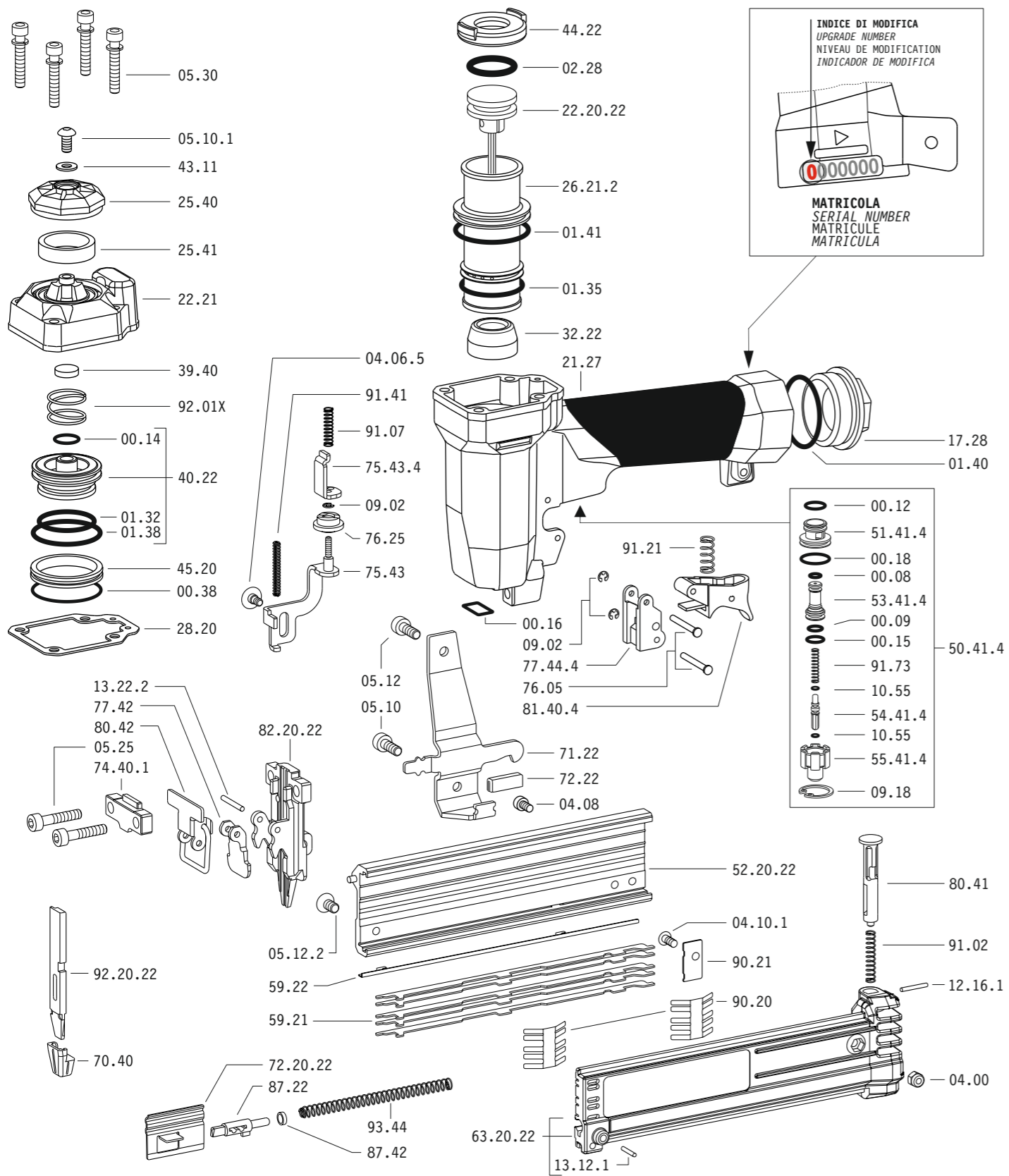

Dotazioni - Equipment - Ausrüstung - Équipements - Equipamiento - Παρεχόμενα
Equipamento - Uitrusting - Udstyr

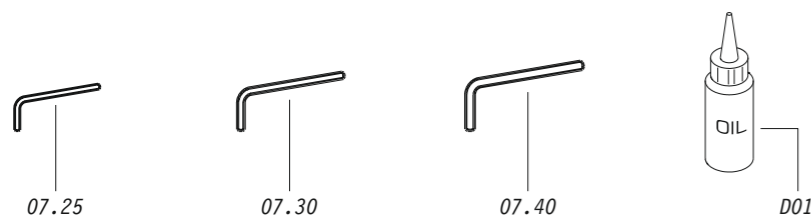

12.40

cod. 1221210

Parti di ricambio - Spare parts - Ersatzteile - Pièces de rechange - Piezas de repuesto
Ανταλλακτικά - Partes sobresselentes - Wisselstukken - Reservedele

Cod.	Descrizione	Description
00.08	O-Ring	O-Ring
00.09	O-Ring	O-Ring
00.12	O-Ring	O-Ring
00.14	O-Ring	O-Ring
00.15	O-Ring	O-Ring
00.16	O-Ring	O-Ring
00.18	O-Ring	O-Ring
00.38	O-Ring	O-Ring
01.32	O-Ring	O-Ring
01.35	O-Ring	O-Ring
01.38	O-Ring	O-Ring
01.40	O-Ring	O-Ring
01.41	O-Ring	O-Ring
02.28	O-Ring	O-Ring
04.00	Dado	Nut
04.06.5	Vite	Screw
04.08	Vite	Screw
04.10.1	Vite	Screw
05.10	Vite	Screw
05.10.1	Vite	Screw
05.12	Vite	Screw
05.12.2	Vite	Screw
05.25	Vite	Screw
05.30	Vite	Screw
07.25	Chiave esagonale	Hex. bar wrench
07.30	Chiave esagonale	Hex. bar wrench
07.40	Chiave esagonale	Hex. bar wrench
09.02	Anello elastico	Elastic ring
09.18	Anello elastico	Elastic ring
10.55	O-Ring	O-Ring
13.12.1	Spina	Pin
12.16.1	Spina	Pin
13.22.2	Spina	Pin
17.28	Tappo	Inlet cap
21.27	Corpo	Body
22.21	Testa	Head
25.40	Deflettore	Exhaust deflector
25.41	Silenziatore	Silencer
26.21.2	Cilindro	Cylinder
28.20	Guarnizione testa	Head gasket
32.22	Ammortizzatore	Bumper
39.40	Guarnizione scarico	Exhaust seal
40.22	Valvola completa	Valve ass'y
43.11	Rondella	Washer
44.22	Guarnizione	Gasket
45.20	Anello valvola	Ring
50.41.4	Pulsante completo	Trigger valve ass'y
51.41.4	Boccola pulsante	Trigger valve housing
53.41.4	Pistone servovalvola	Valve piston
54.41.4	Pulsante	Trigger valve
55.41.4	Raccordo pulsante	Bush
59.21	Distanziale	Spacer
59.22	Spessore	Sliding guide
70.40	Puntale	Contact tip
71.22	Reggicaricatore	Support
72.22	Fermo carrello	Slider-stop
74.40.1	Staffa testina	Nose guide
75.43	Sicura	Safety
75.43.4	Rinvio sicura	Contact arm
76.05	Perno	Pin
76.25	Regolatore	Adjusting wheel
77.42	Guida testina	Safety nose plate
77.44.4	Guida sicura	Safety guide
80.41	Grilletto chiusura	Trigger
80.42	Grilletto testina	Nose plate lock
81.40.4	Grilletto comando	Trigger
87.22	Portamolla	Spring bearing
87.42	Segnalatore	Signal washer
90.20	Molla	Spring
90.21	Staffa distanziale	Spacer holder
91.02	Molla	Spring
91.07	Molla	Spring
91.21	Molla	Spring
91.41	Molla	Spring
91.73	Molla	Spring
92.01X	Molla	Spring
93.44	Molla	Spring
22.20.22	Battente	Driver
52.20.22	Caricatore	Magazine
63.20.22	Carrello	Slider
72.20.22	Spingipunto	Pusher
82.20.22	Controtestina	Nose
92.20.22	Testina	Nose plate
D01	Bocchetta olio	Oiler

Guarnizioni - O-Rings - Dichtungen - Joints - Kit O-rings - Λαστιχάκια - Kit O-rings - Pakninger

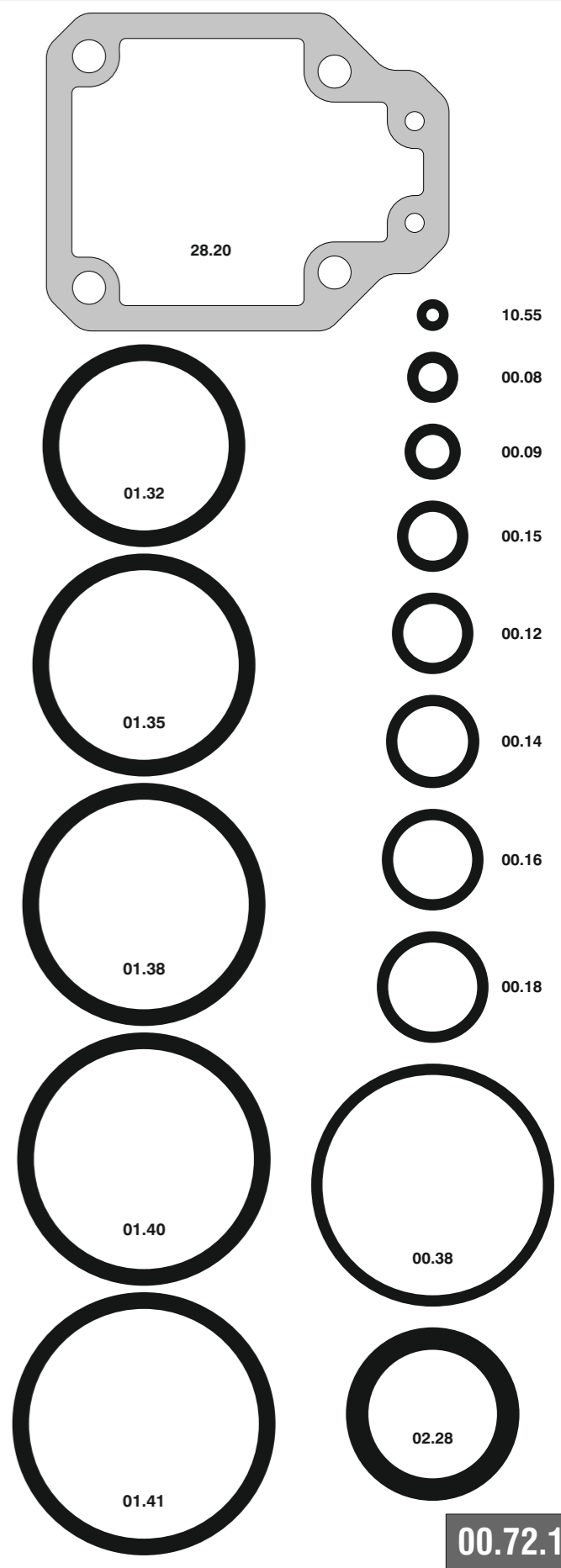

cod. 1221210

Indice di modifica
Upgrade number

2

12.40

Disincaamento - Jam clearing

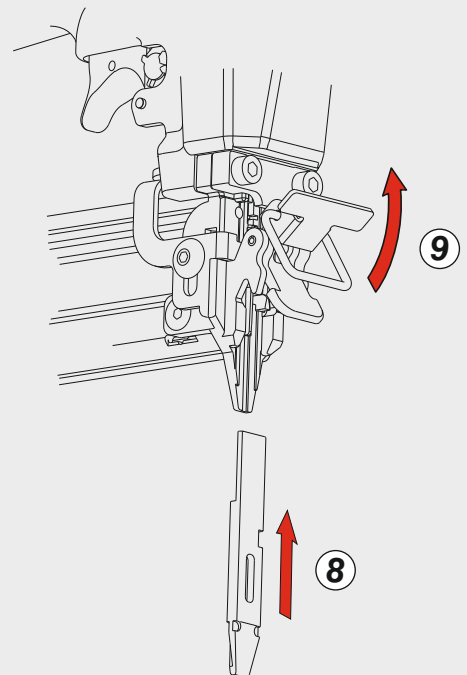
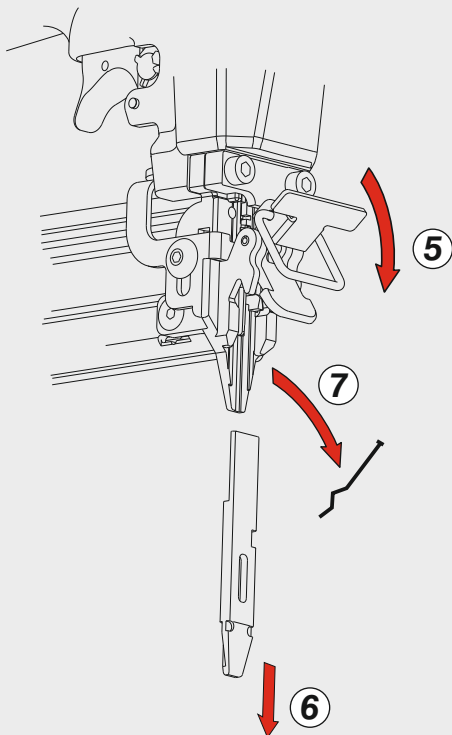
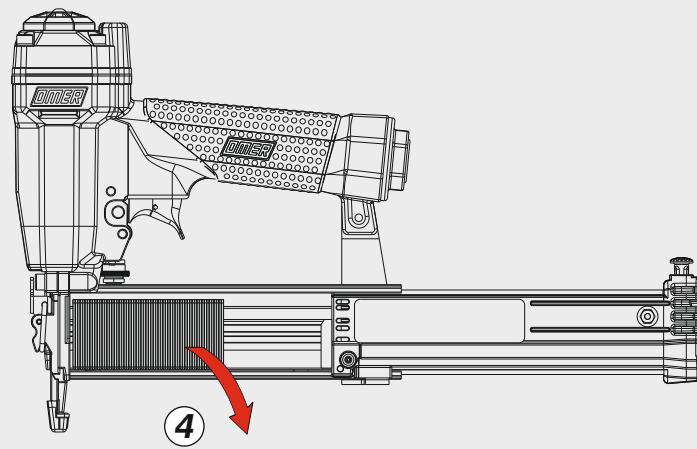
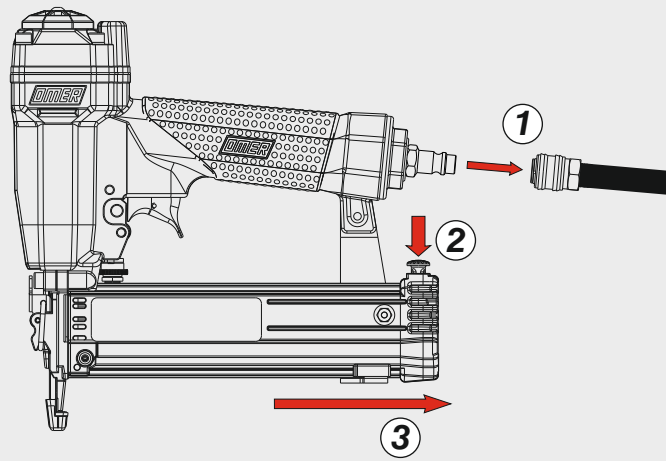

Caratteristiche - Features

Dispositivo di blocco sparo a fine punti
Stop firing device on empty magazine

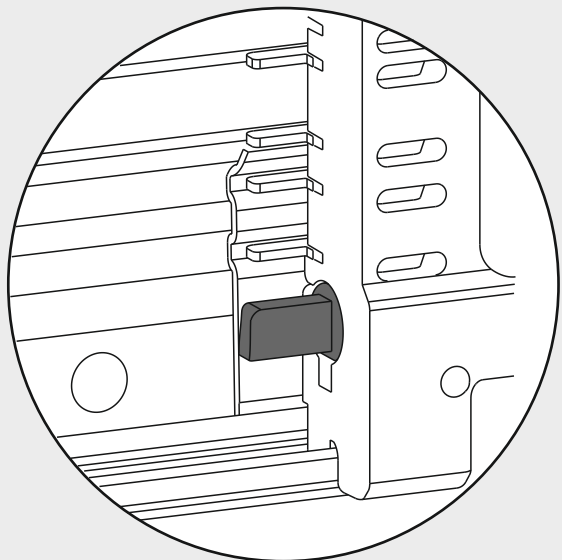

Scarico orientabile a 360°
360° adjustable exhaust

